

THE ORIGINAL



## Fold and Roll™ System

The 3000XP series Fold & Roll Sign System™ utilizes a collapsible leg and panel design for compact storage, also making it easy to transport to and from the work zone. The need for separate storage locations for stand and sign is eliminated. The Dicke patented leg Kick Release and snap-in hub mechanism makes for quick, hassle free set-up allowing crews to be more productive and safer. NCHRP-350 accepted.

- Displays 36" or 48" signs (3000XP series) with double flag holder.
- Sign panel detaches from stand for changeability of legends via the Stablock panel holder (see page 4).
- Shown here: **DF3003S** sign stand with **3000XP-48** Fold & Roll sign panel.

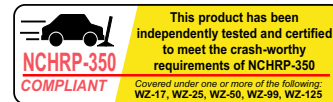

## Quick and Easy Set-Up

Using the patented Dicke Kick Release, quickly lock legs into place. Unwrap velcro strap releasing sign panel. Pull vertical support arm upward locking into place. Finish off set-up by locking horizontal ribs in place by pulling and snapping into hub.

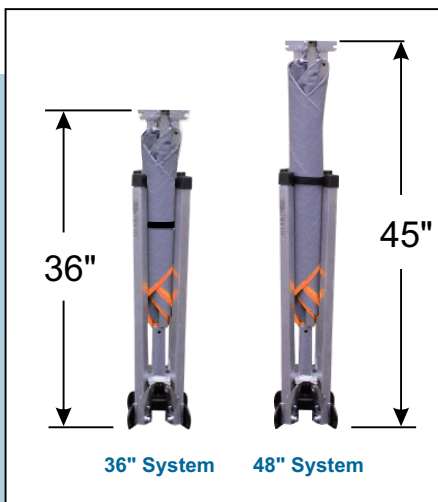

36" System 48" System

Storage Configuration

## Compact System Storage

- Shown with the Dynaflex sign stand. Also available with our Uniflex stand (see page 8).
- When in the storage position, easily located stamp is placed on top of center hub for quick identification of sign legend.
- Model number and weight (sign and stand):

- **DF3000X-36** - 36" System - 21 lbs.
- **DF3003X-48** - 48" System - 24 lbs.



Self-locking center hub, manufactured from steel, creates a secure support for the sign panel assembly.