

# Frontliner

## Fx4

Our Frontliner Fx-series is what sets us apart. They are the highest performing combined cutting and spreading tool on the market. Largely due to the advantages of the Ultimate<sup>BAR</sup>, most of the time the Fx4 has enough spreading performance that you do not have to change to a dedicated spreader. Although it has less power than the Fx6, it has enough capacity to cut everything you normally come across. In most cases you do not need the massive power the Fx6 produces. The Fx4 is lighter and therefore extremely easy to handle. Easily detach the jaws and you have a dedicated cutter. With the same capacity as our G4 cutter you do not have to worry about having enough cutting capacity. The Frontliner FX-series is the choice when time is critical.

### Features:

- Ultimate Pressure
- EWO<sup>technology</sup>
- CCC capacity (Complex Car Constructions)
- Detachable jaws

### Facts:

- Best average power to weight ratio
- Most powerful medium-duty combi tool
- Highest safety factors on critical parts



PRESSURE<sup>™</sup>  
ULTIMATE

Fx4 Frontliner: combining the best of both in one tool

**Advanced blade design:** gives you control over the cutting action from round bar to complex car constructions

**Detachable jaws:** to easily make it into a full capacity dedicated cutter

**Fixed 360° handle:** enables the user to have balance in every position and change positions quickly

**Flat bolt design:** lowers the insertion height of the tool, enabling you to reach confined spaces

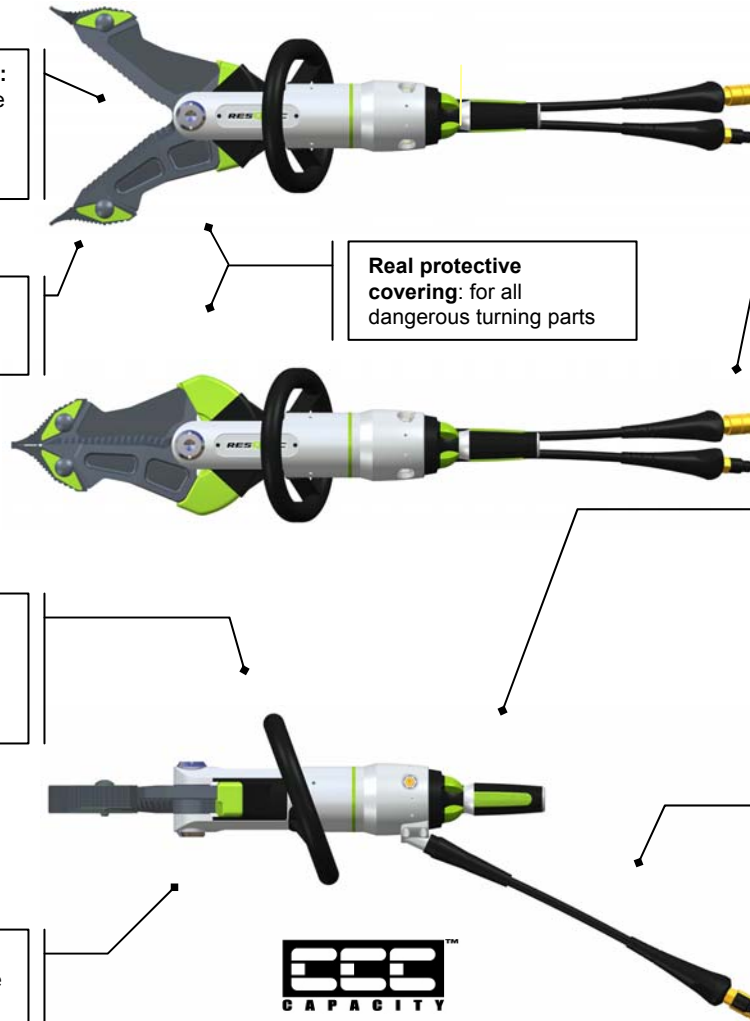

**Real protective covering:** for all dangerous turning parts

**Quick connectors:** easy and fast to connect. Automatic locking and flat-face design prevent sand and dirt from getting in the couplers. A rescuers' favorite

**Duo control:** handle for both thumb and/or twist control in one. Ergonomically designed for best control in every position. No risk to the user as no hydraulics go through the handle.

**360° turning tail-hoses:** so they never interfere with operation and don't take up space when stored. Withstand 8x the working pressure, making them the safest available

Capacity tested for ComplexCarConstructions

FRONTLINER Fx-series

## Technical specifications Fx4

Model	Fx4 Frontliner
Nominal pressure	UltimatePSI™ / 5000 PSI / 350 Bar
Dimensions (LxWxH)	30 1/8" x 8 13/16" x 9 11/16" // 765 x 224 x 246 mm
Operational weight	31,3 lb / 14.2 kg
Max. cutting opening	10 1/8" / 257 mm
Reach	7 9/16" / 143 mm
Max. cutting force	109,669 lbs / 54.8 US tons / 488 kN / 49.7 ton
Max.spreading opening	12 5/8" / 320 mm
Max.spreading force	14,428 lbs / 7.2 US tons / 64.2 kN / 6.5 ton
Max.pulling opening	14 15/16" / 380 mm
Max.pulling force	4.4 US tons / 39.4 kN / 4.0 ton
EN 13204	Compliant
NFPA 1936	Compliant

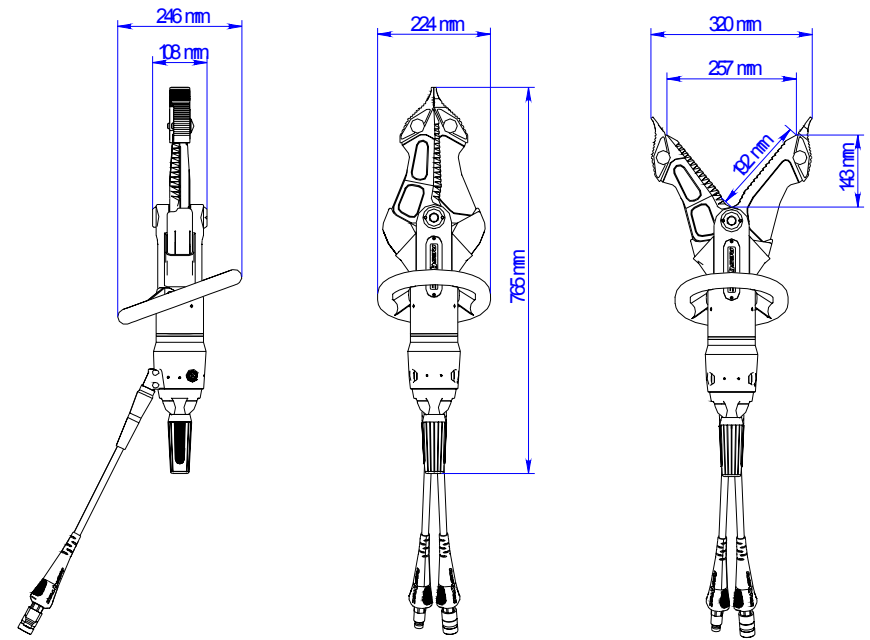

For questions or additional information please e-mail to [info@resqtec.com](mailto:info@resqtec.com)